

P/N	MAT'L	GAGE	WIDTH	LENGTH	QTY
HANDLE KITS:			9"		
DIVIDER KITS:			14421		

**HEAVY DUTY SERIES**

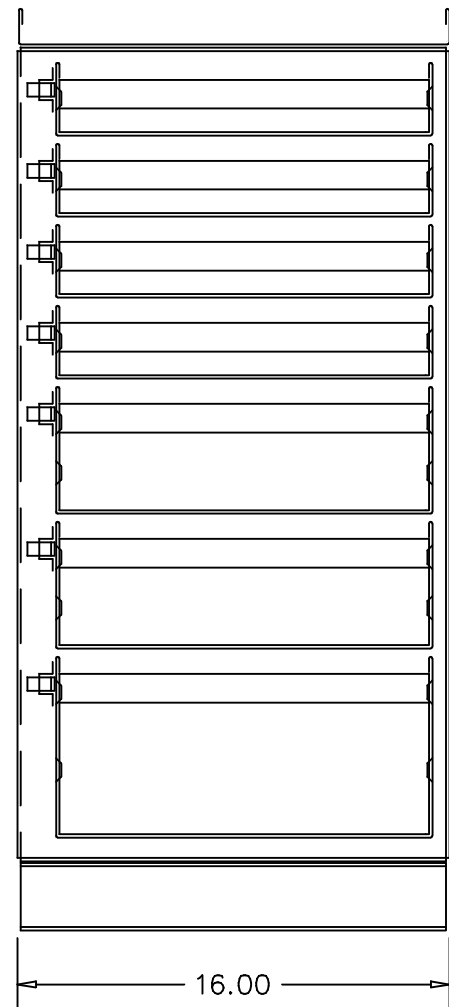
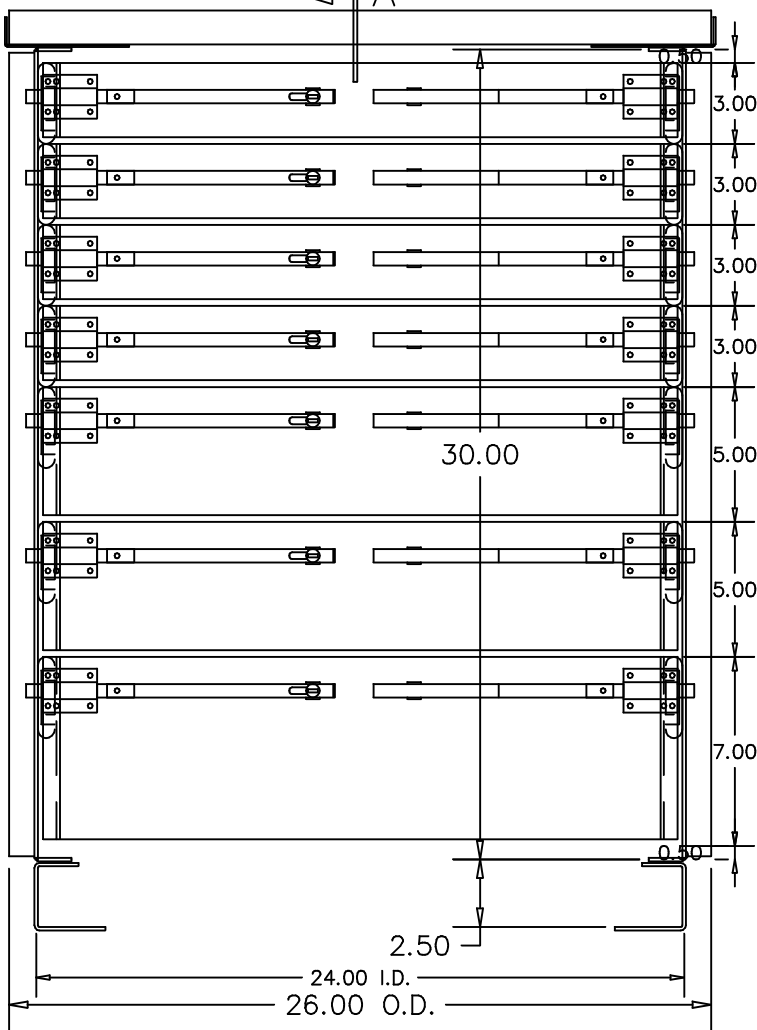
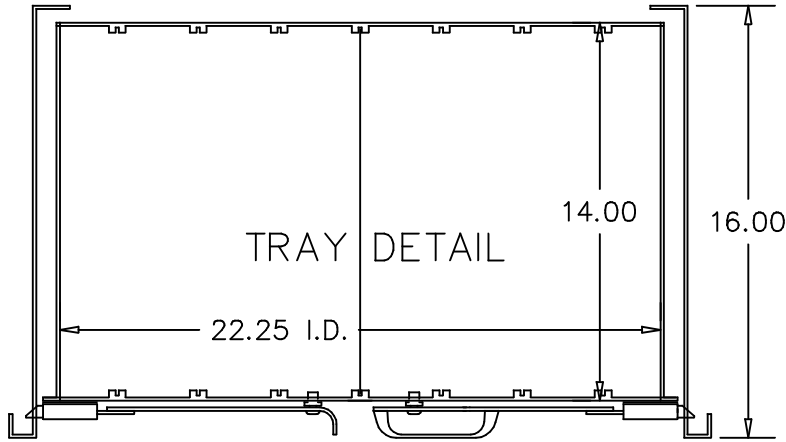

**CUSTOMER APPROVAL**

PLEASE MARKUP OR SIGN AS APPROVED AND FAX BACK TO (801) 363-8119

SIGNED:

P.O. #

DATE: